

AVILO OVRT 1.2

Oil Vapour Removal Tower 1.2 Activated Carbon Adsorber

SPECIFICATIONS

Max. Flow at 7 bar	2 Nm ³ /min
Max. operating pressure	13 bar (g)
Temperature range	2 - 50 °C
Outlet air - oil content	< 0.003 mg/m ³
Feed air - oil content	< 1.0 mg/m ³
Feed air – relative humidity	< 40% (non-condensing)
In/outlet connection	1 "BSP (G)
Dimensions	900 x 280 x 235 mm
Weight	25,5 kg
Change frequency	3.000 hours / annually
Maintenance kit	AVMKOVRT12-01



The Avilo OVRT1.2 Carbon Adsorber reduces all traces of oil vapour, hydrocarbons, ozone and odours from compressed air. Third party validated to meet ISO8573-1 compressed air standard for "technical oil free air".

Description

Both oil-lubricated and oil-free compressors introduce residual oil into compressed air, rendering it unsuitable for applications within the food, beverage, and pharmaceutical industries. Avilo OVRT1.2 successfully addresses this issue by effectively eliminating residual oil, in addition to removing other undesirable contaminants like hydrocarbons and ozone. This ensures that the compressed air meets the stringent purity requirements necessary for applications in sensitive industries.

Unique cartridge design

Unlike conventional loose-filled carbon towers, the adsorbent material is secured in position using a densely packed cartridge and robust coil spring. This prevents the carbon bed from becoming dislodged, minimizing gradual erosion of the adsorbent material, decreasing performance, and potential obstruction of downstream filters. The tight configuration not only ensures efficient adsorption of oil vapors but also maintains unrestricted airflow. Ease of maintenance is a key feature, requiring a straightforward replacement of the prefilled cartridge at the designated interval.

Performance

When combined with 1µ & 0,01µ pre-filtration and fed with compressed air dried by a refrigerant dryer, the adsorber provides air that meets [class 1] or exceeds [class 0] for oil in accordance with ISO8753-1:2010 [third party validated] for a life time of 3000hours.

Unlimited capacity / Multibank

Multiple OVRT units can be positioned adjacently, allowing for an expanded capacity without occupying excessive and costly floor space, thanks to its compact design.

AVILO OVRT 1.2

Oil Vapour Removal Tower 1.2 Activated Carbon Adsorber

Advantages

Effectively Minimizes Oil Vapour Traces

The carbon cartridge modules are filled with premium quality activated pellets possessing exceptional adsorptive capabilities to efficiently reduce all remaining oil vapours within the compressed air.

Odour and Flavor Elimination

The activated carbon's porous structure adsorbs all unwanted odours and flavor compounds from the compressed air, ensuring a high-quality compressed air supply suitable for applications in the food, beverage, and pharmaceutical industries.

Simple and Swift Maintenance Procedure

Replacing the carbon-filled cartridge is a straightforward process, eliminating the time-consuming and messy task of manually exchanging loose carbon material.

Minimal Pressure Drop

The streamlined manifolds, featuring large diameter connections, ensure unrestricted airflow with an impressively low pressure drop of less than 0.05 bar, even at maximum capacity.

Versatile Inlet/Outlet Configuration

The connection manifold's multiple in/outlets provide flexibility in placing the compact unit, also allowing for multi-banking possibilities.

Integrated Filters

While all bed-type adsorbers release carbon dust during usage, our uniquely designed built-in particle filter captures and prevents any carry-over, effectively capturing these carbon particles.

Environmental Responsible

Our product is designed with environmental responsibility in mind, allowing users to effortlessly separate its materials for environmentally conscious disposal.

Capacity

Model	m3/min	Connectie	Multibank
OVRT1.2	2	1"	1
2x OVRT1.2	4	1"	2
3x OVRT1.2	6	1"	3
4x OVRT1.2	8	1"	4
5x OVRT1.2	10	1"	5

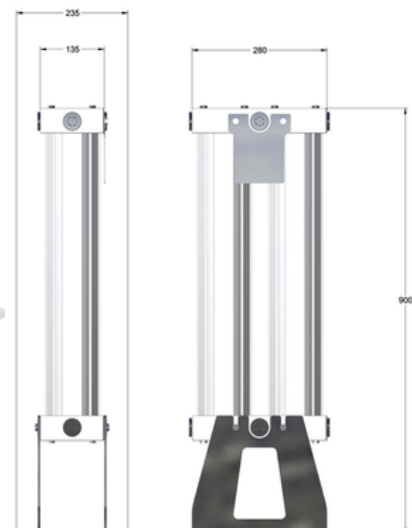

Do you have questions about our range regarding the AVILO OVRT1.2? Please feel free to contact us.

JULY 2024